

Minimizing the Number of Arcs Linking a Permutation of Points in the Plane

Stephane Durocher*

Chris Gray†

James King‡

June 11, 2006

Abstract

Given a finite set of points P in \mathbb{R}^2 and a permutation of P , $f : P \rightarrow P$, what is the minimum number of arcs required to connect the points of P such that every point $p \in P$ is adjacent to $f(p)$ along an arc and no two arcs cross? We show this question is NP-complete.

1 Problem Definition

An *arc* consists of a closed continuous subset of a circle in the plane (the subset may be a complete circle). We generalize this definition to include arcs of a circle of infinite radius, namely, line segments.

For a finite set P , function $f : P \rightarrow P$ defines a *permutation* of P if and only if f is a bijection. That is, f partitions P into ordered cycles.

Definition 1 Let P be a finite set of points in \mathbb{R}^2 . Let $f : P \rightarrow P$ denote a permutation of P . Let A be a set of arcs in \mathbb{R}^2 . Set A is an *arc link* of (P, f) if for every $p \in P$, p and $f(p)$ are adjacent along some arc $a \in A$.

Definition 2 Let P be a finite set of points in \mathbb{R}^2 . Let $f : P \rightarrow P$ denote a permutation of P . Let A be an arc link of (P, f) . If for all $a_1, a_2 \in A$, $a_1 \neq a_2$ implies a_1 and a_2 do not intersect (except possibly at their endpoints) then set A is a *non-crossing arc link* of (P, f) .

Definition 3 Let P be a finite set of points in \mathbb{R}^2 . Let $f : P \rightarrow P$ denote a permutation of P . Let A be a non-crossing arc link of (P, f) . If $|A| \leq |B|$ for any set B that is a non-crossing arc link of (P, f) , then set A is a *minimum non-crossing arc link* of (P, f) .

See Figure 1. The question can be phrased as a decision problem by including the value k :

MINIMUM NON-CROSSING ARC LINK

INSTANCE:

Let P be a finite set of points in \mathbb{R}^2 . Let $f : P \rightarrow P$ define a permutation of P . Let $k \in \mathbb{Z}^+$ be fixed.

*Department of Computer Science, University of British Columbia, durocher@cs.ubc.ca

†Department of Mathematics and Computer Science, TU Eindhoven, cgray@win.tue.nl This research was supported by GOIDE Networks of Centres of Excellence.

‡School of Computer Science, McGill University, jking@cs.mcgill.ca

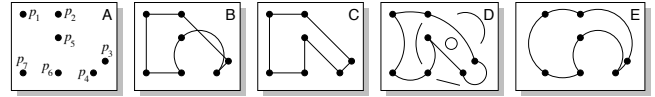

Figure 1: (A) a set of points $P = \{p_1, \dots, p_7\}$ with a simple cyclic permutation, $f(p_i) = p_j$, where $j = i + 1 \pmod{7}$, (B) an arc link of (P, f) , (C) and (D) non-crossing arc links of (P, f) , and (E) a minimum non-crossing arc link of (P, f) consisting of three arcs

QUESTION:

Does there exist a set A that is a non-crossing arc link of (P, f) such that $|A| \leq k$?

2 Related Work

Given a set of points P and a permutation $f : P \rightarrow P$, a simple related problem would be to determine whether a non-crossing edge link exists, where edges are line segments. At most one solution exists if only straight edges are allowed and minimizing the cardinality of the edge link is unnecessary. The existence of a solution is easily verified in $O(n \log n)$ time by running a sweep-line algorithm [1] to detect intersections among the edges.

A related problem is given by removing the requirement that points of P be linked in order according to permutation f . The corresponding question asks whether there exists an arc cover of P , regardless of the order in which points are linked (the cover need not be a cycle cover). That is, given a set of points P in \mathbb{R}^2 and an integer k , can P be covered by a set of k line segments? This problem was shown to be NP-hard by Megiddo and Tamir [6]. Algorithms solving this problem in time exponential in k are given by Langerman and Morin [4].

3 Reduction from P3SAT

We show MINIMUM NON-CROSSING ARC LINK is NP-hard by a polynomial-time reduction from P3SAT (planar 3-satisfiability).

P3SAT

INSTANCE:

Let $L = \{x_1, \dots, x_n\}$ be a finite set of literals and let $\bar{L} = \{\bar{x}_1, \dots, \bar{x}_n\}$ be the corresponding set of negated

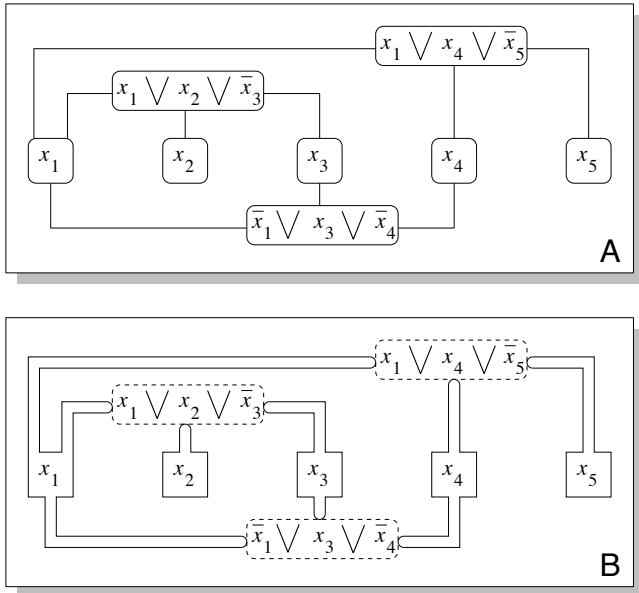

Figure 2: non-crossing embedding of P3SAT instance

literals. Let $C \subseteq (L \cup \bar{L}) \times (L \cup \bar{L}) \times (L \cup \bar{L})$ be a set of clauses, where each clause $c \in C$ is a disjunction of three literals drawn from $L \cup \bar{L}$ such that the induced bipartite graph, $G = (L, C, E)$, is planar, where the edge set $E \subseteq L \times C$ is defined by $E = \{(x, c)\}$, where literal x or \bar{x} appears in clause c .

QUESTION:

Does there exist a set of literal truth values $L \subseteq \{T, F\}^n$ such that all clauses in C are satisfied?

There exists a non-crossing embedding of G in the plane such that all literal vertices (set L) are positioned along the x -axis on a unit grid [3, 5]. We will assume that an instance of P3SAT refers to such an embedding; that is, the three literals of each clause are connected by three vertical line segments and at most three horizontal line segments. The meeting point of the edges forms a vertex of degree three corresponding to the clause. See Figure 2A.

Deciding whether an instance of P3SAT has a satisfying truth assignment is NP-complete [5].

Theorem 1 *MINIMUM NON-CROSSING ARC LINK is NP-complete.*

Proof. We describe a polynomial-time reduction from P3SAT to MINIMUM NON-CROSSING ARC LINK and show that a solution can be verified in polynomial time.

Choose any instance I of P3SAT (we may assume each literal is contained within at most five clauses [2, 5]). Let $G_I = (L, C, E)$ denote a non-crossing embedding in the plane of the bipartite graph induced by

I such that the vertices of L lie on the unit grid along the x -axis, the vertices of C lie at grid points above or below the x -axis, and all edges $(x, c) \in E$ consist of one vertical line segment and at most one horizontal line segment whose union connects $x \in L$ and $c \in C$.

We build a point set P and an associated permutation f in polynomial time such that, for a certain integer k that we determine, (P, f) has a non-crossing arc link of size less than or equal to k if and only if I is satisfiable.

We construct gadgets, where each gadget consists of a point set along with a permutation of that point set. We build a gadget for each clause and a gadget for each literal. As for edges, every edge in G_I has one literal endpoint and one clause endpoint. The edges will not have their own gadgets, but rather these will be like tentacles extending from the literal gadgets (see Figure 2B). These tentacles will reach out and interact with the appropriate clause gadgets.

The gadget (P_x, f_x) for the literal x will admit exactly two minimum arc links, A_x (black) and A'_x (grey), each of size $|P_x|/2$. These arc links represent the use of x and \bar{x} respectively. The gadget (P_c, f_c) for the clause c will admit a non-crossing arc link of size 11 if and only if our choice of arc links for the literal gadgets satisfies the clause. For an unsatisfied clause, the corresponding clause gadget will only admit arc links of size strictly greater than 11. Our problem instance will simply be the union of the gadgets, i.e.,

$$P = \left[\bigcup_{x \in L} P_x \right] \cup \left[\bigcup_{c \in C} P_c \right]$$

and

$$f = \left[\bigcup_{x \in L} f_x \right] \cup \left[\bigcup_{c \in C} f_c \right].$$

We set our integer k as

$$k = 11|C| + \frac{1}{2} \sum_{x \in L} |P_x|.$$

This value of k means that (P, f) will admit a non-crossing arc link of size k if and only if, for every literal x either A_x or A'_x is used, and every clause gadget is satisfied by this assignment and uses an arc link of size 11.

The gadget (P_x, f_x) for the literal x is such that no four consecutive points are co-circular. A_x and A'_x are both such that any arc connects at most three consecutive points. Therefore A_x and A'_x must be the only two minimum arc links for (P_x, f_x) . A_x and A'_x both follow the horizontal and vertical edges between literal x and the clause vertices for all clauses to which x belongs (see Figures 2B and 3). A_x and A'_x essentially trace the same shape, with only minor differences. The differences come into play only when the tentacles interact with the clause gadgets.

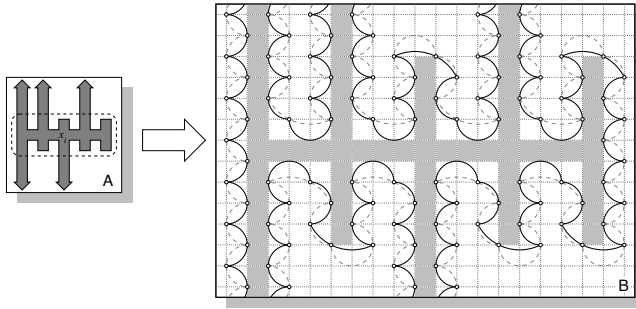

Figure 3: The point set P_x representing the vertex x and all adjacent edges in the P3SAT graph. The grey strips extending out of the frame in (B) represent edges going from x to clause vertices. A_x and A'_x are shown in (B) outlining the shape of the gadget.

Following the outline of the desired shape of the gadget for a literal x requires some of the tricks shown in Figure 4. When a clause includes the negation of a literal, we negate the polarity using the inverter gadget displayed in Figure 4C.

For our clause gadgets we translate each clause into the negation of a disjunction. For example, take the clause $c = x_1 \vee x_2 \vee x_3$ and rewrite it as $\overline{\overline{x_1} \wedge \overline{x_2} \wedge \overline{x_3}}$. The permutation for the clause gadget consists of three 3-cycles. The corresponding points are positioned such that the circles induced by the 3-cycles intersect each other (see Figures 5 and 6). Each clause is met by three literals, each of which interacts with one of the three circles. That is, each circle is intersected by exactly one of the minimum arc links for the corresponding literal gadget (see Figure 6). For a literal x , this is where the difference between A_x and A'_x actually matters. Finally, a blocking gadget is inserted along the circle between two of the points in each 3-cycle. This blocking gadget prevents these two points from being linked by an arc of the circle (see Figure 5B).

Thus, for each clause $c \in C$, the clause gadget consists

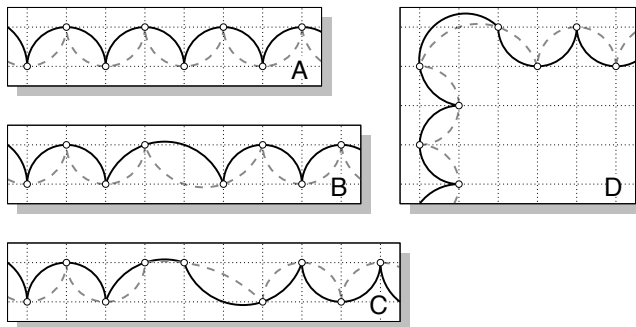

Figure 4: (A) a literal gadget x_i and $\overline{x_i}$, (B) an offset gadget, (C) a polarity inverter gadget, and (D) a right-angle turn gadget

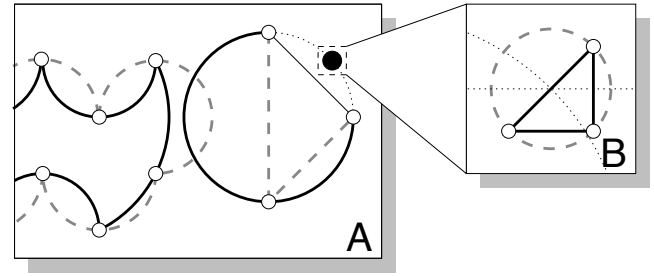

Figure 5: (A) clause gadget component and (B) blocking gadget

of the set P_c of 18 points and the permutation f_c . A minimum arc link of (P_c, f_c) must include one of the three circular arcs. This means that at least one of the three literal gadgets must have the desired truth assignment, i.e., the desired minimum arc link. Observe that a minimum arc link of (P_c, f_c) consists of 11 arcs.

The clause gadget will admit a non-crossing arc link of size 11 if and only if the variable assignment (i.e., choice of minimum arc links for the literal gadgets) satisfies the clause. Thus, (P, f) will admit a non-crossing arc link of size k if and only if the original P3SAT instance is satisfiable.

It is not difficult to see that the reduction can be done in polynomial time. A solution can be verified in $O(n^2)$ time by examining every pair of arcs and checking whether they intersect. Therefore MINIMUM NON-CROSSING ARC LINK is NP-complete.

4 Open Problems

Given a set of points P and a permutation f , we have shown that the problem of finding a minimum non-crossing arc link is NP-complete.

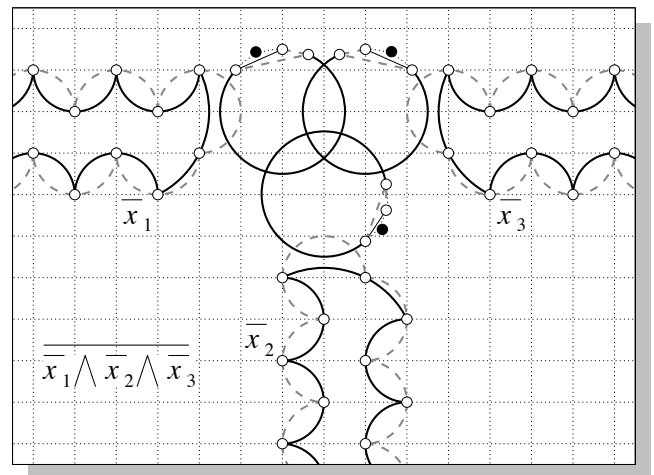

Figure 6: clause $x_1 \vee x_2 \vee x_3 \equiv \overline{\overline{x_1} \wedge \overline{x_2} \wedge \overline{x_3}}$

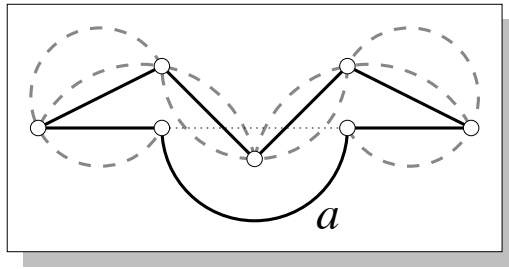

Figure 7: There exists a set P and a permutation f such that any non-crossing arc link of (P, f) must include a curved arc that only meet two points of P .

For some sets of points P and permutations f no non-crossing arc link of (P, f) consists only of line segments (see Figure 7). Furthermore, for some sets of points P and permutations f , no non-crossing arc link of (P, f) exists (see Figure 8).

To our knowledge, given a set of points P in \mathbb{R}^2 and a permutation $f : P \rightarrow P$, the complexity of determining whether there exists any (not necessarily minimum) non-crossing arc link of (P, f) is open. We formally state the problem below:

NON-CROSSING ARC LINK

INSTANCE:

Let P be a finite set of points in \mathbb{R}^2 . Let $f : P \rightarrow P$ define a permutation of P .

QUESTION:

Does there exist a non-crossing arc link of (P, f) ?

Whether NON-CROSSING ARC LINK is NP-hard or polynomial-time solvable remains an open question.

Acknowledgements

The authors would like to thank the members of the theory group in the Department of Computer Science at the University of British Columbia where this problem was initially discussed at a problem-solving session.

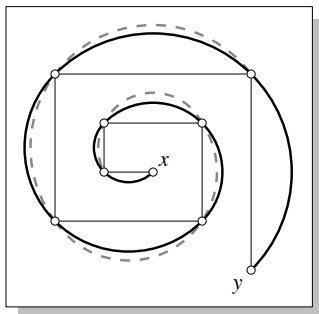

Figure 8: No non-crossing arc link exists if $p(x) = y$ completes the cycle.

References

- [1] M. de Berg, M. van Kreveld, M. Overmars, and O. Schwarzkopf. *Computational Geometry Algorithms and Applications*. Springer-Verlag, Berlin Heidelberg, 1997.
- [2] M. R. Garey and D. S. Johnson. *Computers and Intractability*. W. H. Freeman and Company, New York, 1979.
- [3] D. E. Knuth and A. Raghunathan. The problem of compatible representatives. *SIAM Journal of Discrete Mathematics*, 5(3):422–427, 1992.
- [4] S. Langerman and P. Morin. Covering things with things. *Discrete and Computational Geometry*, 33:717–729, 2005.
- [5] D. Lichtenstein. Planar formulae and their uses. *SIAM Journal of Computing*, 11(2):329–343, 1982.
- [6] N. Megiddo and A. Tamir. On the complexity of locating linear facilities in the plane. *Operations Research Letters*, 1(5):194–197, 1982.